

## Simple Controller for Fast Charge Systems

### Description

The bipolar IC U2407B is a fast charge battery controller for drained NiCd/ NiMH batteries. Apart from phase control, it is identical with U2405B, but has four LED outputs. It enables an efficient and economic charge system. It incorporates an intelligent multiple gradient battery voltage monitoring combined with temperature and failure mode detection. With automatic top-off

charging, the integrated circuit enables the charge device to stop regular charging, before the critical stage of overcharging can occur. It incorporates an additional algorithm for reactivating fully drained batteries especially after long time storage. It has four LED driver outputs for different indications of the charge status.

### Features

- Multiple gradient monitoring
- Temperature window ( $T_{min}/T_{max}$ )
- Exact currentless measurement
- Four LED status outputs
- Linear power control
- Preferred for externally regulated current sources
- Preformation algorithm for drained batteries
- Programmable top-off charge function

### Applications

- Primary switch mode
- AC/ DC wall plug adapter
- Ultra fast charger (10 minute)

**Package:** DIP16/ SO16

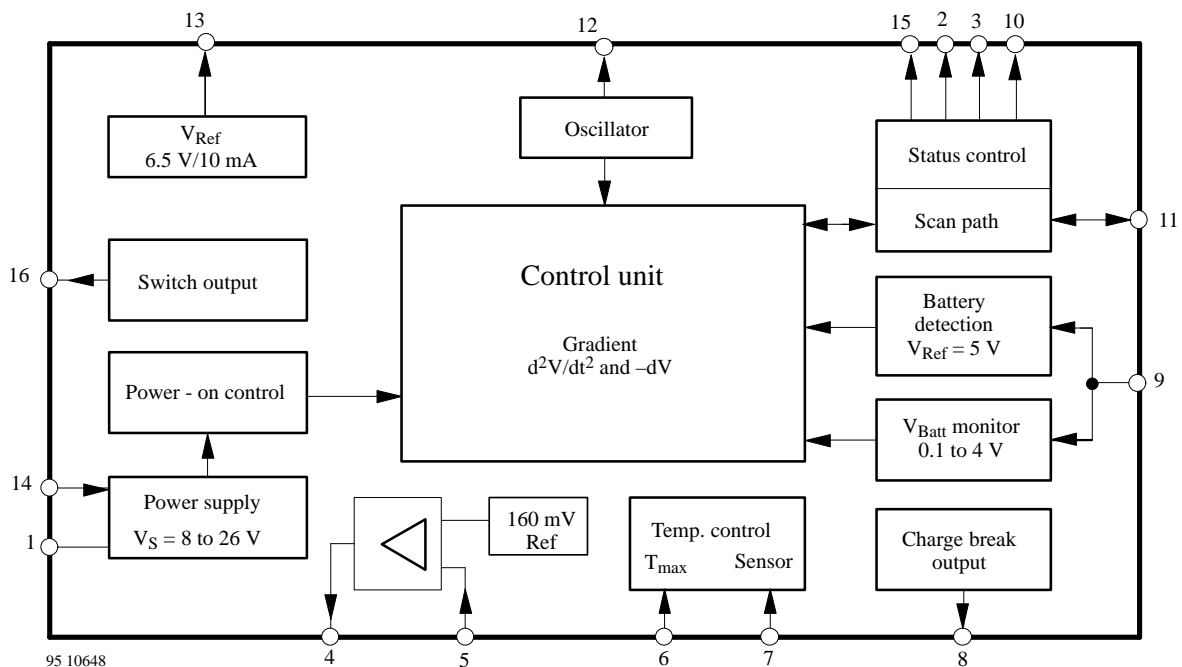

Figure 1. Block diagram

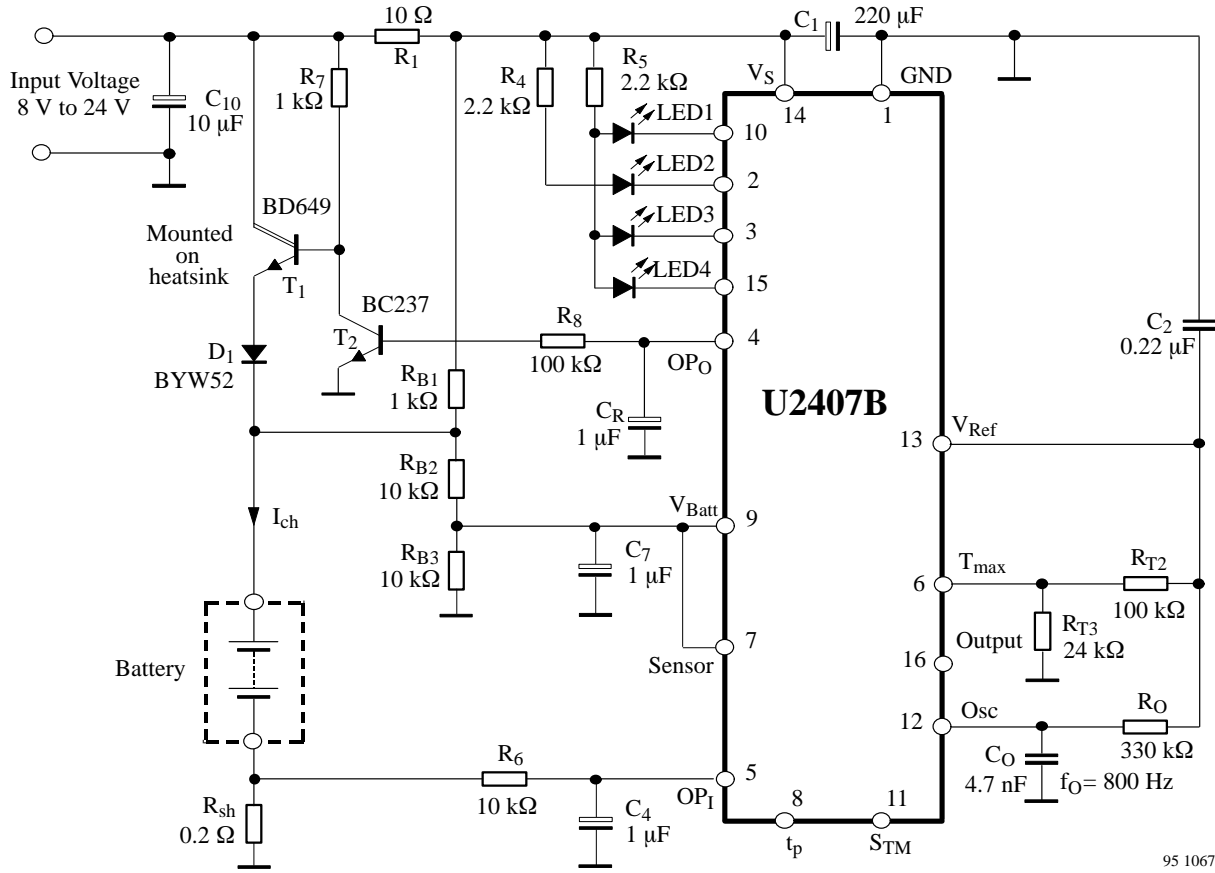
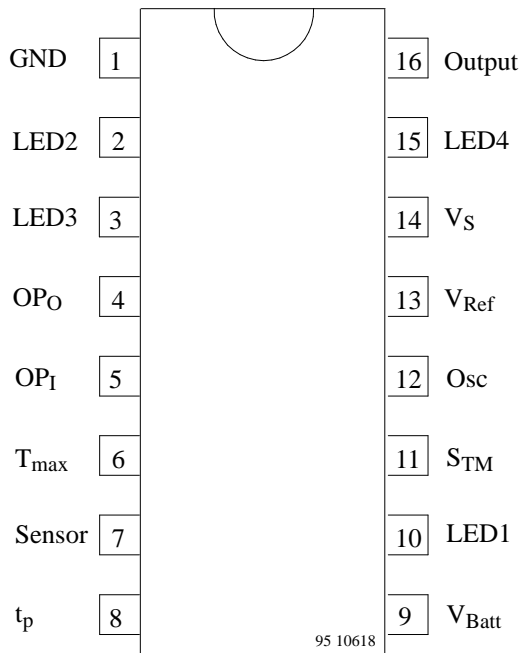

Figure 2. Scheme for DC linear regulation

## Pin Description

Package: DIP16/ SO16



Pin	Symbol	Function
1	GND	Ground
2	LED2	Display output "top-off/ trickle charge"
3	LED3	Display output "Fast charge"
4	OPo	Operational amplifier output
5	OPi	Operational amplifier input
6	T <sub>max</sub>	Maximum temperature
7	Sensor	Temperature sensor
8	t <sub>p</sub>	Charge break output
9	V <sub>Batt</sub>	Battery voltage
10	LED1	Display output "failure mode"
11	S <sub>TM</sub>	Test mode switch (status control)
12	Osc	Oscillator
13	V <sub>Ref</sub>	Reference output voltage
14	V <sub>S</sub>	Supply voltage
15	LED4	Display output "top-off charge"
16	Output	Trigger output

## General Description

The integrated circuit, U2407B, is designed for charging Nickel-Cadmium (NiCd) and Nickel-Metal-Hydride (NiMH) batteries. Fast charging results in voltage lobes when fully charged (figure 3). It supplies two identifications (i.e.,  $+ d^2V/dt^2$ , and  $- dV$ ) to end the charge operation at the proper time.

As compared to the existing charge concepts where the charge is terminated – after voltage lobes – according to  $- dV$  and temperature gradient identification, the U2407B takes into consideration the additional changes in positive charge curves, according to the second derivative of the voltage with respect to time ( $d^2V/dt^2$ ). The charge identification is the sure method of switching off the fast charge before overcharging the battery. This helps to give the battery a long life by hindering any marked increase in cell pressure and temperature.

Even in critical charge applications, such as a reduced charge current or with NiMH batteries where weaker

charge characteristics are present multiple gradient control results in very efficient switch-off.

An additional temperature control input increases not only the performances of the charge switching characteristics but also prevents the general charging of a battery whose temperature is outside the specified window.

A specific preformation algorithm is implemented for reactivating fully drained batteries especially in the case of batteries that have been stored for a long time.

A constant charge current is necessary for continued charge-voltage characteristic. This constant current is generated from an external power supply and can be regulated with the help of an internal op-amp regulator (figure 2). An external current source can also be controlled by the switch output Pin 16 (see figure 12).

For further information please refer to the applications.

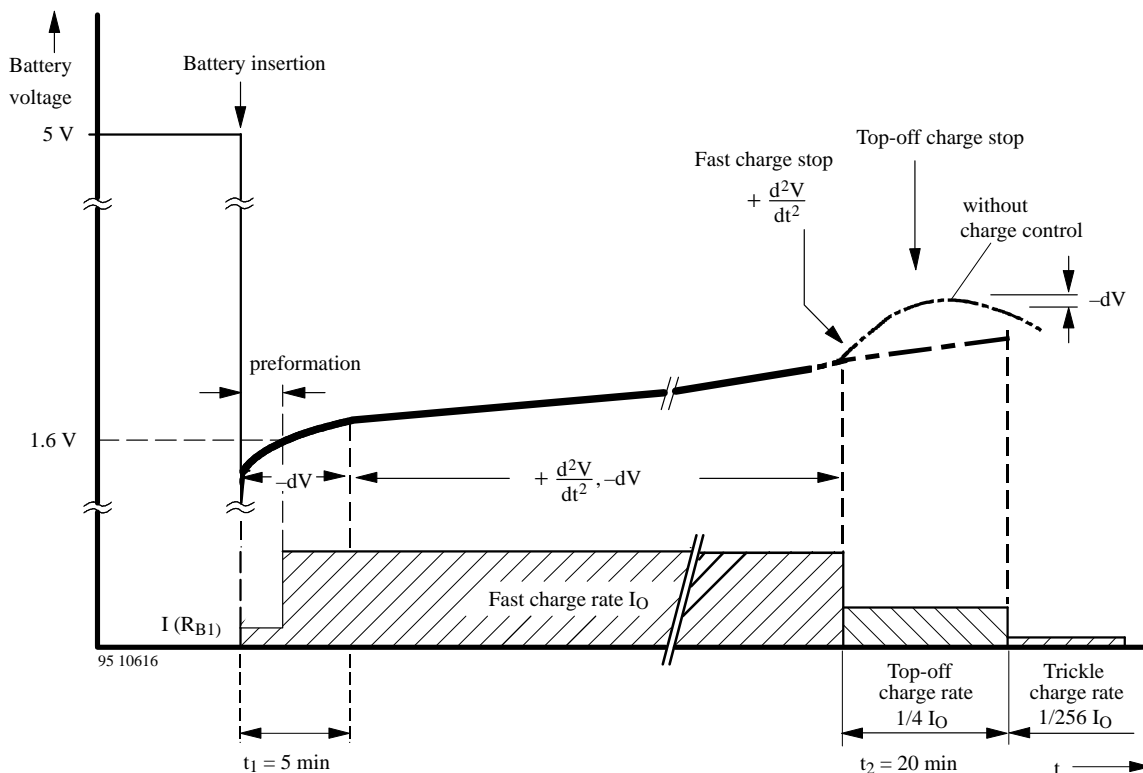

Figure 3. Charge function diagram,  $f_{osc} = 800 \text{ Hz}$

## Flow Chart Explanation, $f_{osc} = 800 \text{ Hz}$ (Figures 2, 3 and 4)

Battery pack insertion disables the voltage lock at battery detection input Pin 9. All functions in the integrated circuit are reset. For further description, DIP-pinning is taken into consideration.

### Battery Insertion and $-dV$ Monitoring

After battery insertion fast charge  $I_o$  begins normally when the input voltage  $V_{Batt}$  is higher than 1.6 V. For the first 5 minutes the  $d^2V/dt^2$ -gradient recognition is suppressed,  $-dV$  monitoring is activated. In case the detected  $V_{Batt}$  voltage is less than 1.6 V the special preformation procedure will be activated. The reference level with respect to the cell voltage can be adjusted by the resistor  $R_{B3}$  (see figure 2).

### Preformation Procedure

Before fast charge of fully drained or long time stored batteries begins, a reactivation of it is necessary. The preformation current is dependent on pull-up resistor  $R_{B1}$ . The fast charge starts only after the  $V_{Batt}$  is higher than 1.6 V. During the first 10 minutes the green LED2 is blinking. If after 10 minutes,  $V_{Batt}$  voltage has not reached the reference level, the indication changes to red blinking LED1. The charge will continue with preformation rate  $I(R_{B1})$ . In case  $V_{Batt}$  increases to 1.6 V reference level, the fast charge rate current  $I_o$  is switched-on and the green LED2 is blinking.

### $-dV$ Cut-Off (Monitoring)

When the signal at Pin 9 of the DA converter is 12 mV below the actual value, the comparator identifies it as a voltage drop of  $-dV$ . The validity of  $-dV$  cut-off is considered only if the actual value is below 12 mV for three consecutive cycles of measurement.

### $d^2V/dt^2$ -Gradient

If there is no charge stop within the first 5 minutes after battery insertion, then  $d^2V/dt^2$  monitoring will be active. In this actual charge stage, all stop-charge criteria are active.

When close to the battery's capacity limit, the battery voltage curve will typically rise. As soon as the  $+d^2V/dt^2$  stop-charging criteria are met, the device will stop the fast charge activities.

### Top-Off Charge Stage

By charge disconnection through the  $+d^2V/dt^2$  mode, the device switches automatically to a defined protective top-off charge with a pulse rate of  $1/4 I_o$  (pulse time,  $t_p = 5.12 \text{ s}$ , period,  $T = 20.48 \text{ s}$ ).

The top-off charge time is specified for a time of 20 minutes @ 800 Hz.

During top-off mode the LED4 is in ON mode.

### Trickle Charge Stage

When top-off charge is terminated, the device switches automatically to trickle charge with  $1/256 I_o$  ( $t_p = 5.12 \text{ s}$ , period = 1310.72 s). The trickle continues until the battery pack is removed.

During trickle mode the LED2 output is in on mode, LED4 is in OFF-mode.

## Basic Description

### Power Supply, Figure 2

The charge controller allows the direct power supply of 8 V to 26 V at Pin 15. Internal regulation limits higher input voltages. Series resistance,  $R_1$ , regulates the supply current,  $I_S$ , to a maximum value of 25 mA. Series resistance is recommended to suppress the noise signal, even below 26 V limitation. It is calculated as follows.

$$R_{1min} \geq \frac{V_{max} - 26 \text{ V}}{25 \text{ mA}}$$

$$R_{1max} \leq \frac{V_{min} - 8 \text{ V}}{I_{tot}}$$

where

$$I_{tot} = I_S + I_{RB1} + I_1$$

$$V_{max}, V_{min} = \text{Rectified voltage}$$

$$I_S = \text{Current consumption (IC) without load}$$

$$I_{RB1} = \text{Current through resistance, } R_{B1}$$

$$I_1 = \text{Trigger current at Pin 1}$$

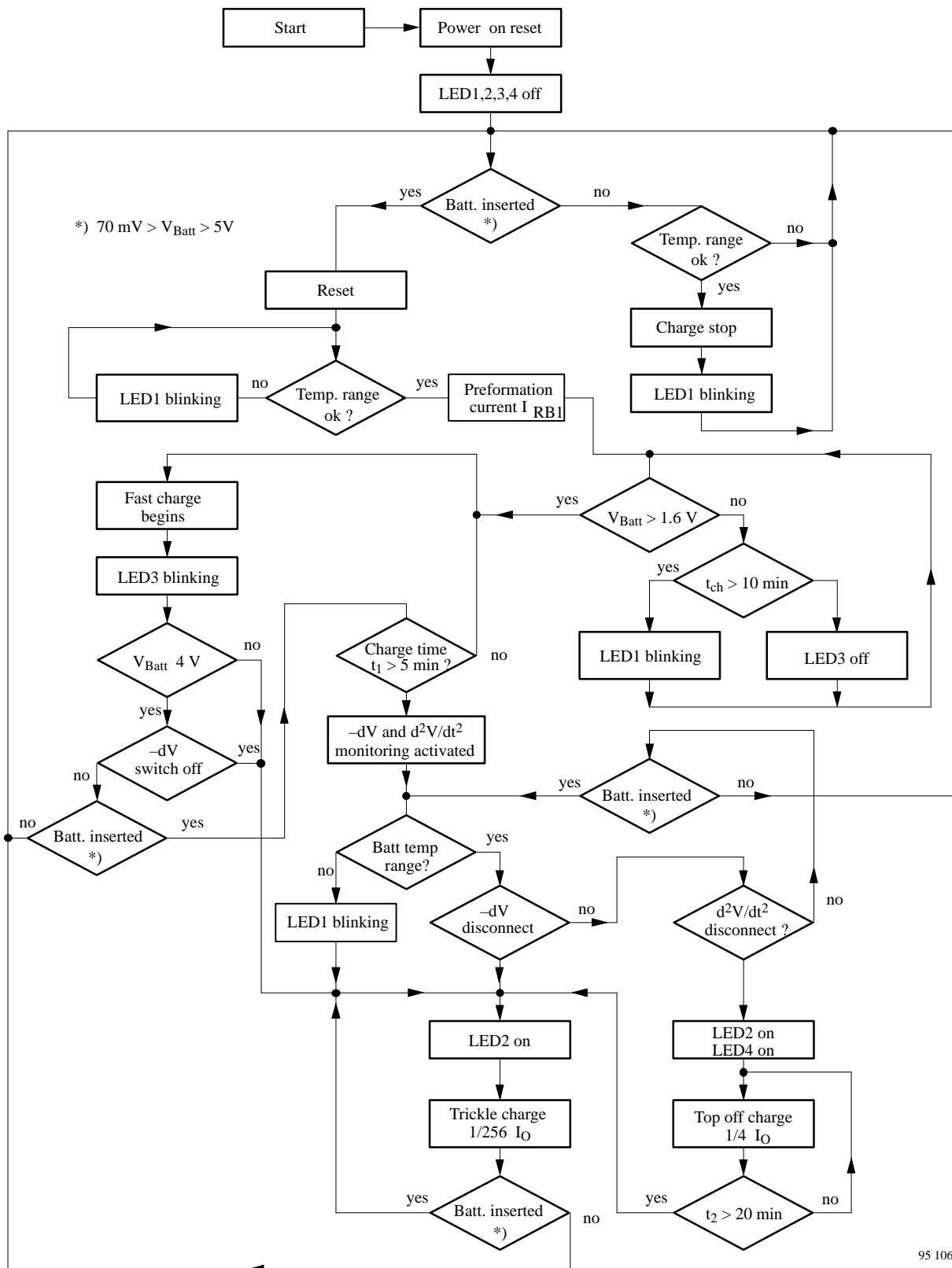

95 10671

Figure 4. Flow chart

## Battery Voltage Measurement

The battery voltage measurement at Pin 9 (ADC-converter) has a range of 0 V to 4 V, which means a battery pack containing two cells can be connected without a voltage divider.

If the AD converter is overloaded ( $V_{Batt} \geq 4 V$ ) a safety switch-off occurs. The fast charge cycle is terminated by automatically changing to trickle charge.

Precaution should be taken that under specified charge current conditions, the final voltage at the input of the converter, Pin 9, should not exceed the threshold voltage level of the reset comparator, which is 5 V. When the battery is removed, the input (Pin 9) is terminated across the pulled-up resistance,  $R_{B1}$ , to the value of 5 V-reset-threshold. In this way, the start of a new charge sequence is guaranteed when a battery is reinserted.

If the battery voltage exceeds the converter range of 4 V, adjusting it by the external voltage divider resistance,  $R_{B2}$  and  $R_{B3}$  is recommended.

Values of the resistances,  $R_{B1}$ ,  $R_{B2}$  and  $R_{B3}$  are calculated by assuming  $R_{B1} = 1 k\Omega$ ,  $R_{B2} = 10 k\Omega$ , as follows:

$$R_{B3} = R_{B2} \frac{V_{10max}}{V_{Battmax} - V_{10max}}$$

The minimum supply voltage,  $V_{Smin}$ , is calculated for reset function after removing the inserted battery according to:

$$V_{Smin} = \frac{0.03mA \cdot R_{B3}(R_{B1} + R_{B2}) + 5V (R_{B1} + R_{B2} + R_{B3})}{R_{B3}}$$

where:

- $V_{10max}$  = Max voltage at Pin 10
- $V_{Smin}$  = Min supply voltage at the IC (Pin 15)
- $V_{Battmax}$  = Max battery voltage

The voltage conditions mentioned above are measured during charge current break (switch-off condition).

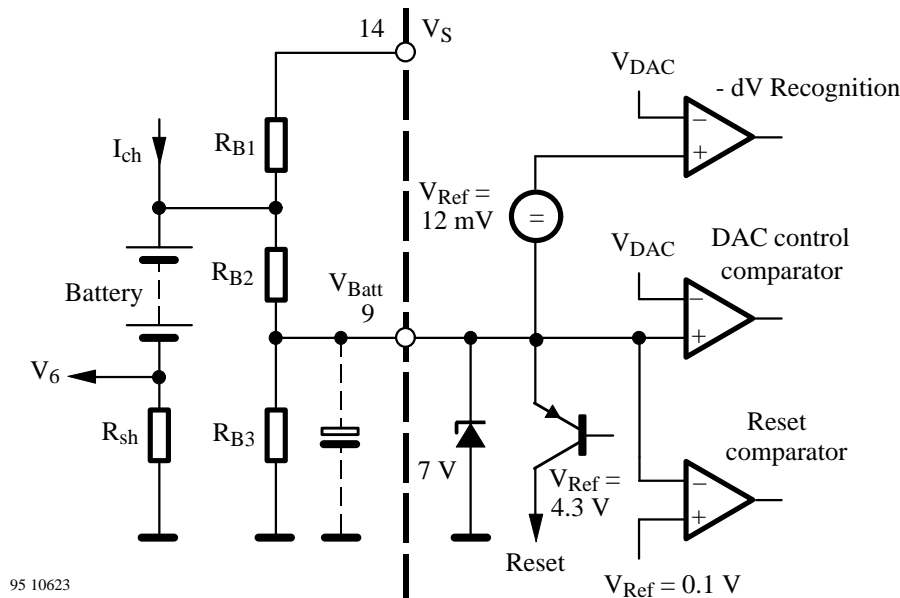

Figure 5. Input configuration for the battery voltage measurement

Table 1. valid when  $V_{10max} = 3.5 V$

Cell No.	1	2	3	4	5	6	7	8	9	10	11	12
$V_{Smin}$ (V)	8	8	8	9	11	13	15	17	19	21	23	25
$R_{B3}$ (k $\Omega$ )	-	-	51	16	10	7.5	5.6	4.7	3.9	3.3	3	2.7

## Analog-Digital-Converter (ADC), Test Sequence

A special analog-digital-converter consists of a five-bit coarse and a five-bit fine converter. It operates by a linear count method which can digitalize a battery voltage of 4 V at Pin 9 in 6.5 mV steps of sensitivity.

In a duty cycle,  $T$ , of 20.48 s, the converter executes the measurement from a standard oscillator frequency of  $f_{osc} = 800$  Hz. The voltage measurement is during the charge break time of 2.56 s (see figure 6), i.e., no-load voltage (or currentless phase). Therefore it has optimum measurement accuracy because all interferences are cut-off during this period (e.g., terminal resistances or dynamic load current fluctuations).

After a delay of 1.28 s the actual measurement phase of 1.28 s follows. During this idle interval of cut-off conditions, battery voltage is stabilized and hence measurement is possible.

An output pulse of 10 ms appears at Pin 8 during charge break after a delay of 40 ms. The output signal can be used in a variety of way, e.g., synchronising the test control (reference measurement).

## Plausibility for Charge Break

There are two criteria considered for charge break plausibility:

### – dV Cut-Off

When the signal at Pin 9 of the DA converter is 12 mV below the actual value, the comparator identifies it as a voltage drop of  $-dV$ . The validity of  $-dV$  cut-off is considered only if the actual value is below 12 mV for three consecutive cycles of measurement.

### $d^2V/dt^2$ Cut-Off

A four bit forward/ backward counter is used to register the slope change ( $d^2V/dt^2$ ,  $V_{Batt} - \text{slope}$ ). This counter is clocked by each tracking phase of the fine AD-counter. Beginning from its initial value, the counter counts the first eight cycles in forward direction and the next eight cycles in reverse direction. At the end of 16 cycles, the actual value is compared with the initial value. If there is a difference of more than two LSB-bit (13.5 mV) from the actual counter value, then there is an identification of slope change which leads to normal charge cut-off. A second counter in the same configuration is operating in parallel with eight clock cycles delay, to reduce the total cut-off delay, from 16 test cycles to eight test cycles.

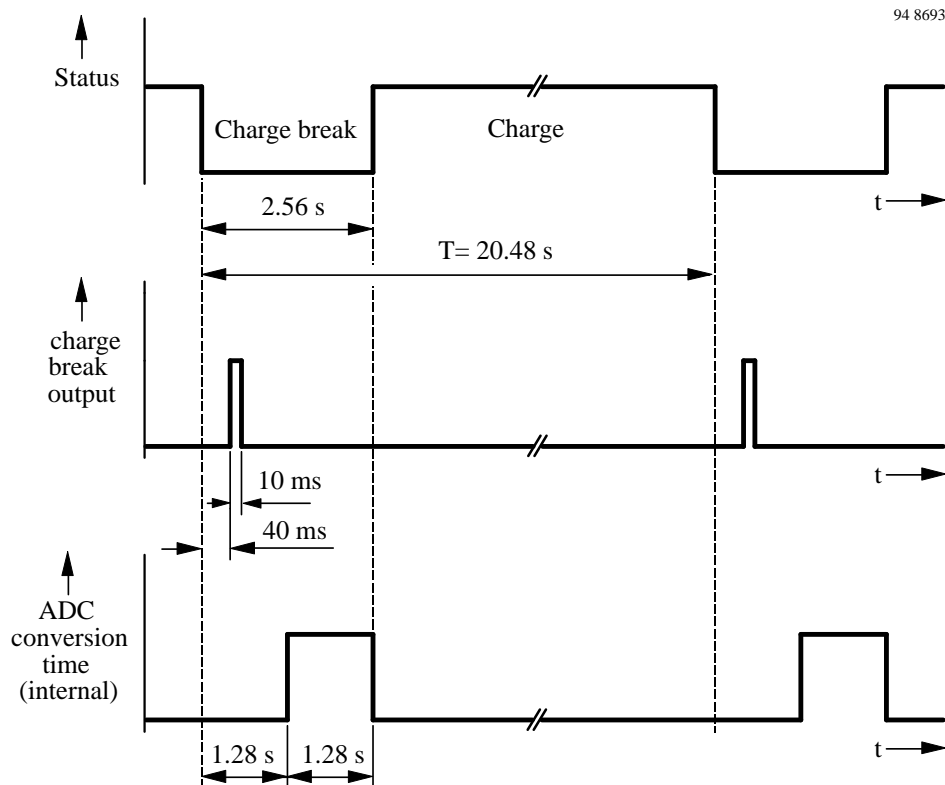

Figure 6. Operating sequence of voltage measurements

## Temperature Control, Figure 7

When the battery temperature is not inside the specified temperature windows, the overall temperature control will not allow the charge process. Sensor short circuit or interruption also leads to switch-off (faulty mode).

A permanent switch-off follows after a measurement period of 20.48 s, if the temperature exceeds a specified level, which is denoted by a status of LED1. A charge sequence will start only when the specified window temperature range is attained.

The temperature window is specified between two voltage transitions. The upper voltage transition is specified by the internal reference voltage of 4 V, and the lower voltage transition is represented by the external voltage divider resistances  $R_{T2}$  and  $R_{T3}$ .

NTC sensors are normally used to control the temperature of the battery pack. If the resistance values of NTC are known for maximum and minimum conditions of allowable temperature, then other resistance values,  $R_{T1}$ ,  $R_{T2}$  and  $R_{T3}$  are calculated as follows:

suppose  $R_{T2} = 100 \text{ k}\Omega$ , then

$$R_{T1} = R_{NTCmax} \frac{V_{Ref} - 4V}{4V}$$

$$R_{T3} = R_{NTCmin} \frac{R_{T2}}{R_{T1}}$$

If NTC sensors are not used, then select the circuit configuration according to figure 10.

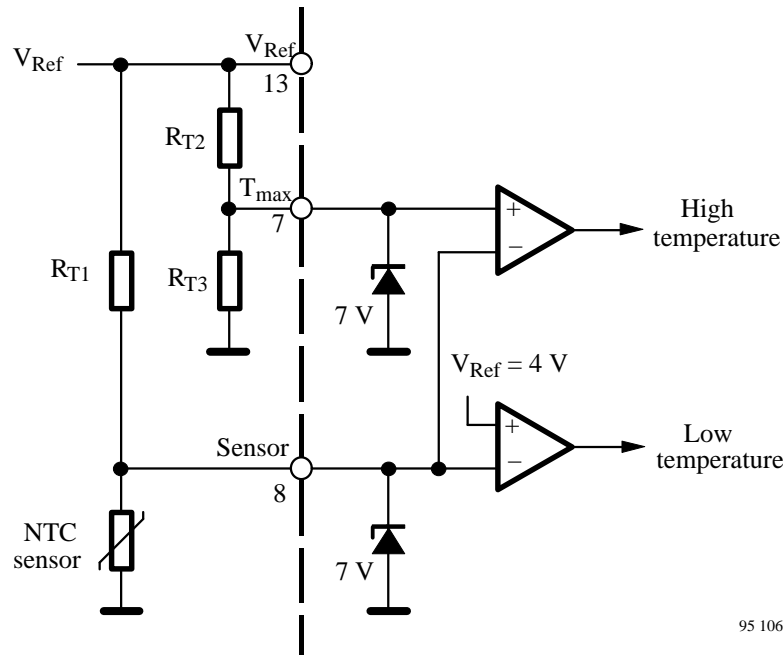

95 10622

Figure 7. Temperature window



## Current Regulation

The charge concept requires a constant charge current supply outside of the circuit. This is achieved by an external switchable current source or by an internal error amplifier regulation of an externally situated power stage.

## Status Control

Different status control modes can be designed by four LED outputs. Status control regards the running charge cycle before it has been started and also after it has been terminated.

LED1	LED2	LED3	LED4	Status
OFF	OFF	OFF	OFF	No battery ( $V_{\text{Batt}} > 5 \text{ V}$ )
OFF	OFF	Blinking	OFF	Fast charge
OFF	ON	OFF	ON	Top-off charge
OFF	ON	OFF	OFF	Trickle charge
Blinking	OFF	OFF	OFF	Failure mode

Failure mode: Temperature out of window, also before battery insertion or power-on.  
Battery break, short circuit,  $V_{\text{Batt}} < 0.1 \text{ V}$

To achieve custom specific display modes, several combinations between LED outputs 1 to 4 are recommended. (see applications)

Example 1:

Display mode similar to U2402B-C and U2405B:

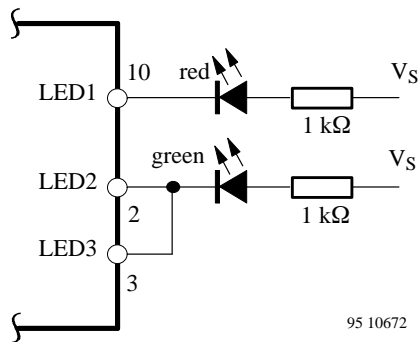

Figure 8.

LED1 (red) (LED1)	LED2 (green) (LED2/ LED3)	Status
OFF	OFF	No battery ( $V_{\text{Batt}} > 5 \text{ V}$ )
OFF	Blinking	Fast charge
OFF	ON	Top-off, trickle charge
Blinking	OFF	All failure mode

Example 2:

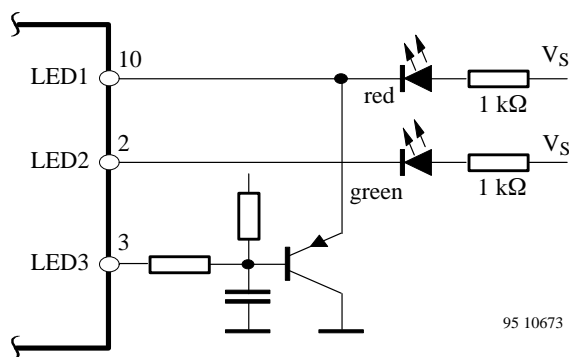

Figure 9.

LED1 (red) (LED1/ LED3)	LED2 (green) (LED2)	Status
OFF	OFF	No battery ( $V_{\text{Batt}} > 5 \text{ V}$ )
ON	OFF	Fast charge
OFF	ON	Top-off, trickle charge
Blinking	OFF	All failure mode

## U2407B

### Top-off Charge Rate Reduction

The current amplitude during top-off charge can be reduced as shown in figure 10. During top-off mode, both the LED4 output (Pin 15) and transistor T are on. The actual current amplitude is influenced with the help of resistor  $R_x$ , which is detected by the operational amplifier input  $OP_1$  (Pin 5). The decrease of the current flow depends on the reciprocal value of  $R_x$ .

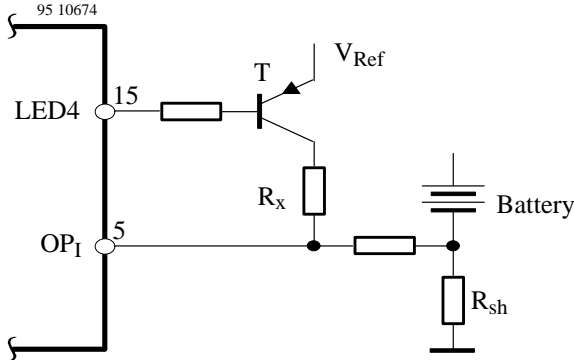

Figure 10.

### Oscillator

Time sequences regarding measured values and evaluation are determined by the system oscillator. All the technical data given in the description are with the standard frequency 800 Hz.

It is possible to alter the frequency range in a certain limitation. Figure 11 shows the frequency versus resistance curves with different capacitance values.

### Oscillation Frequency Adjustment

Recommendations:

0.5C charge	$0.5 \times 800 \text{ Hz} =$	400 Hz
1C charge		800 Hz
2C charge	$2 \times 800 \text{ Hz} =$	1600 Hz
3C charge	$3 \times 800 \text{ Hz} =$	2400 Hz

For further details please refer to the U2402B application note (Chapter 'Setting the Measuring Rate, Using the Oscillator Frequency').

Note: The application note is basing on U2402B/ 2405B pinning, which is different from U2407B.

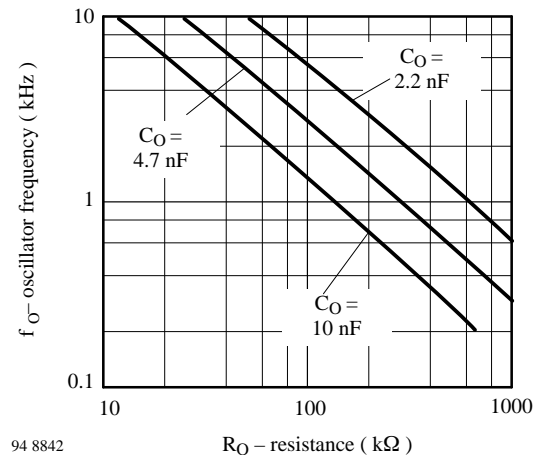

Figure 11. Frequency versus resistance for different capacitance values

### Absolute Maximum Ratings

Reference point Pin 2 (GND), unless otherwise specified

Parameters	Symbol	Value	Unit
Supply voltage Pin 14	$V_S$	26	V
Voltage limitation $I_S = 10 \text{ mA}$		31	
Current limitation Pin 15 $t < 100 \mu\text{s}$	$I_S$	25 100	mA
Voltages at different pins Pins 16, 2, 3, 10 and 15 Pins 11 up to 13, 4 up to 9	V	26 7	V
Currents at different pins Pin 1 Pins 3 up to 14 and 16 up to 18	I	25 10	mA
Power dissipation $T_{amb} = 60^\circ\text{C}$	$P_{tot}$	650	mW
Ambient temperature range	$T_{amb}$	- 10 to 85	$^\circ\text{C}$
Junction temperature	$T_j$	125	$^\circ\text{C}$
Storage temperature range	$T_{stg}$	- 40 to 125	$^\circ\text{C}$

## Thermal Resistance

Parameters	Symbol	Maximum	Unit
Junction ambient	$R_{thJA}$	100	K/W

## Electrical Characteristics

$V_S = 12\text{ V}$ ,  $T_{amb} = 25^\circ\text{C}$ , reference point Pin 1 (GND), unless otherwise specified

Parameters	Test Conditions / Pins	Symbol	Min.	Typ.	Max.	Unit
<b>Power supply</b> Pin 14						
Voltage range		$V_S$	8		26	V
Power-on threshold	ON	$V_S$	3.0		3.8	V
	OFF		4.7		5.7	V
Current consumption	without load	$I_S$	3.9		9.1	mA
<b>Reference</b> Pin 13						
Reference voltage	$I_{Ref} = 5\text{ mA}$	$V_{Ref}$	6.19	6.5	6.71	V
	$I_{Ref} = 10\text{ mA}$		6.14	6.5	6.77	V
Reference current		$-I_{Ref}$			10	mA
Temperature coefficient		TC		-0.7		mV/K
<b>Operational amplifier OP</b>						
Output voltage range	$I_5 = 0$ Pin 4	$V_4$	0.15		5.8	V
Output current range	$V_5 = 3.25\text{ V}$ Pin 4	$I_4$	-80		+80	$\mu\text{A}$
Output pause current	Pin 4	$I_{\text{pause}}$	-130		-100	$\mu\text{A}$
Non-inverting input voltage	Pin 5	$V_5$	0		5	V
Non-inverting input current	Pin 5	$I_5$	-0.5		0.5	$\mu\text{A}$
<b>Comparator or temperature control</b>						
Input current	Pin 6, 7	$I_{6,7}$	-0.5		0.5	$\mu\text{A}$
Input voltage range	Pin 6, 7	$V_{6,7}$	0		5	V
Threshold voltage	Pin 7	$V_7$	3.85		4.15	V
<b>Charge break output</b> Pin 8						
Output voltage	$I_8 = 0$	$V_8$	0		8.4	V
Output current		$I_8$			10	mA
<b>Battery input</b> Pin 9						
Input voltage for ADC		$V_{Batt}$	0		4.0	V
Input current	$0.1\text{ V} \leq V_{Batt} \leq 4.5\text{ V}$	$-I_{Batt}$			0.5	$\mu\text{A}$
Input voltage for reset		$V_{Batt}$	4.8	5.0	5.3	V
Input current for reset	$V_{Batt} \geq 5\text{ V}$	$I_{Batt}$	8		35	$\mu\text{A}$
Battery detection	Maximum voltage	$\Delta V_{Batt}$	80		120	mV
Hysteresis	Maximum voltage	$V_{hys}$		15		mV
<b>Mode select</b> Pin 11						
Threshold voltage	Testmode	$V_{11}$			4,7	V
Input current		$I_{11}$	20			$\mu\text{A}$
Input current	Normal mode Pin 11 open			0		
<b>Sync. oscillator</b> Pin 12						
Frequency	$R = 750\text{ k}\Omega$ , $C = 2200\text{ pF}$	$f_{osc}$		800		Hz
Threshold voltage	High level	$V_{T(H)}$		$4.3 \pm 3\%$		V
	Low level	$V_{T(L)}$		$2.2 \pm 3\%$		
Input current		$I_{12}$	-0.5		0.5	$\mu\text{A}$

# U2407B

## Applications:

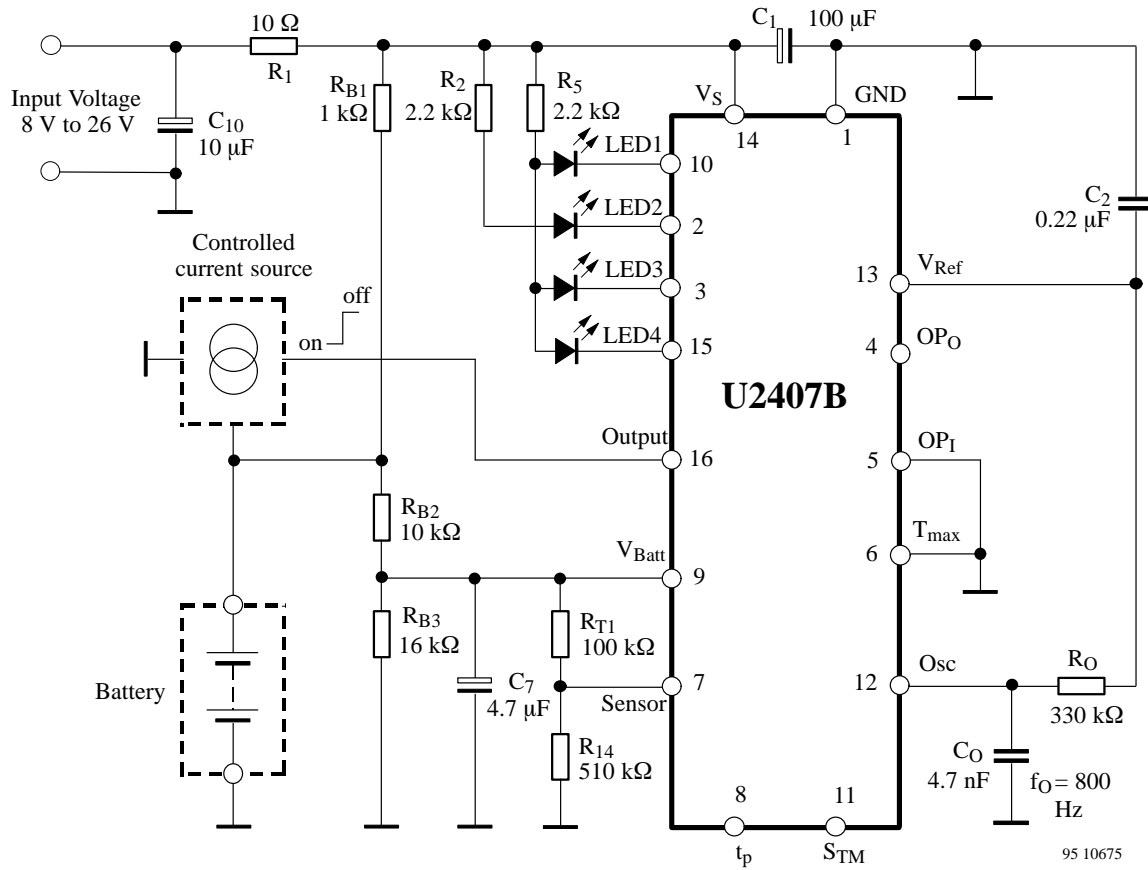
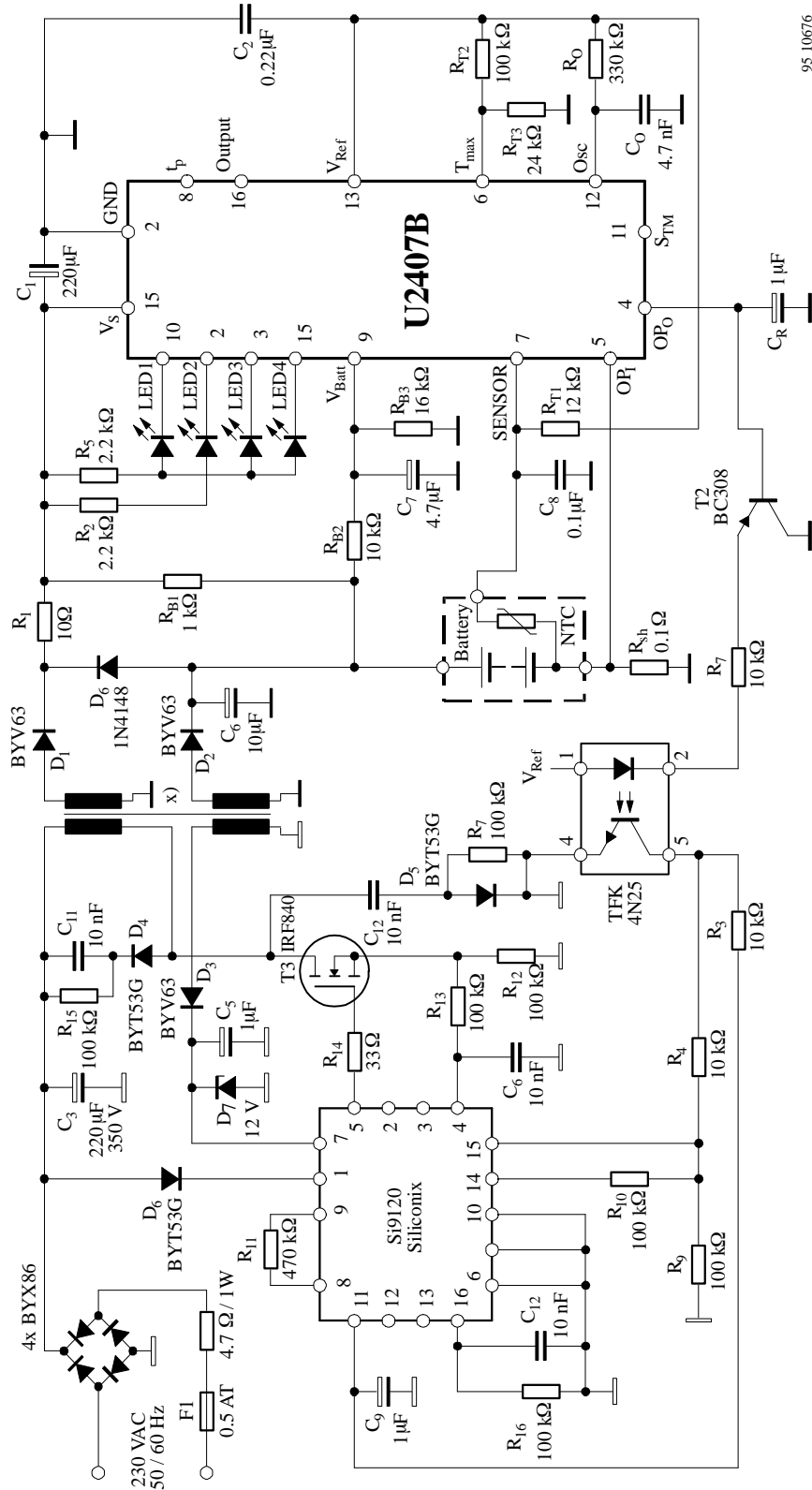

Figure 12. Minimum charge system with external current source



95 10676

x) Fa. Pikatron

Figure 13. Charge system with primary switch-mode power supply

# U2407B

# TEMIC

TELEFUNKEN Semiconductors

## Dimensions in mm

Package: DIP16

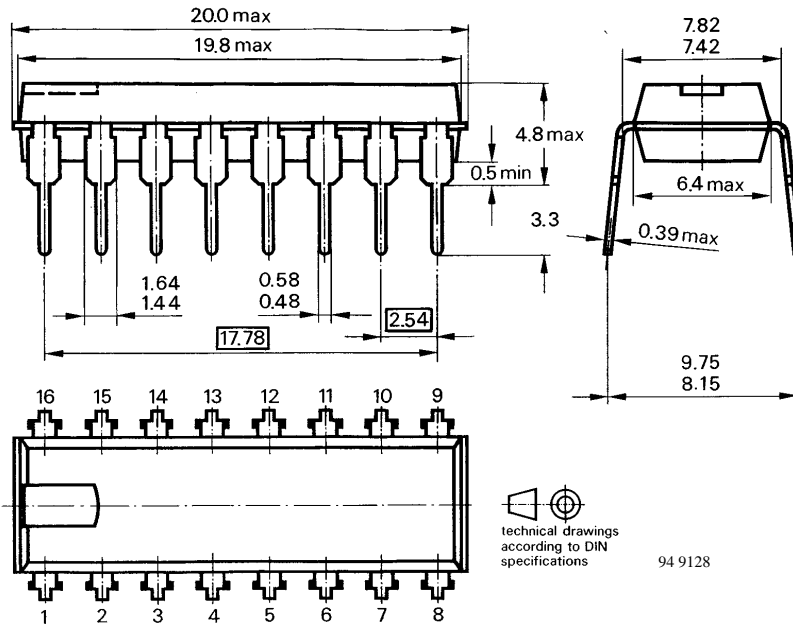

Package: SO16

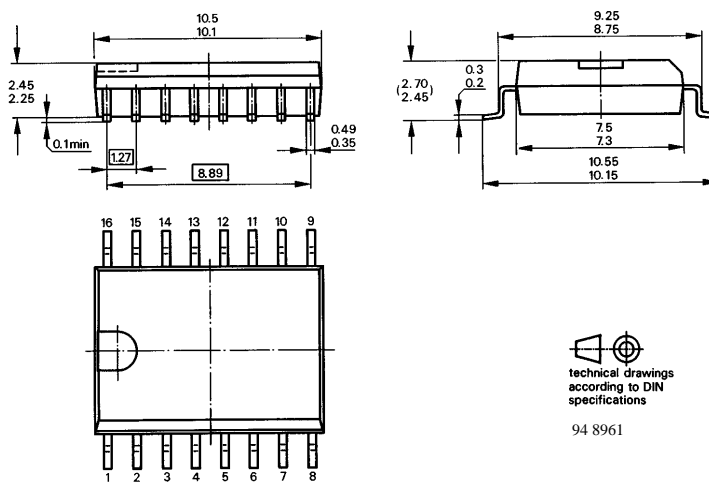

## Ozone Depleting Substances Policy Statement

It is the policy of **TEMIC TELEFUNKEN microelectronic GmbH** to

1. Meet all present and future national and international statutory requirements.
2. Regularly and continuously improve the performance of our products, processes, distribution and operating systems with respect to their impact on the health and safety of our employees and the public, as well as their impact on the environment.

It is particular concern to control or eliminate releases of those substances into the atmosphere which are known as ozone depleting substances (ODSs).

The Montreal Protocol (1987) and its London Amendments (1990) intend to severely restrict the use of ODSs and forbid their use within the next ten years. Various national and international initiatives are pressing for an earlier ban on these substances.

**TEMIC TELEFUNKEN microelectronic GmbH** semiconductor division has been able to use its policy of continuous improvements to eliminate the use of ODSs listed in the following documents.

1. Annex A, B and list of transitional substances of the Montreal Protocol and the London Amendments respectively
2. Class I and II ozone depleting substances in the Clean Air Act Amendments of 1990 by the Environmental Protection Agency (EPA) in the USA
3. Council Decision 88/540/EEC and 91/690/EEC Annex A, B and C (transitional substances) respectively.

**TEMIC** can certify that our semiconductors are not manufactured with ozone depleting substances and do not contain such substances.

**We reserve the right to make changes to improve technical design and may do so without further notice.**

Parameters can vary in different applications. All operating parameters must be validated for each customer application by the customer. Should the buyer use TEMIC products for any unintended or unauthorized application, the buyer shall indemnify TEMIC against all claims, costs, damages, and expenses, arising out of, directly or indirectly, any claim of personal damage, injury or death associated with such unintended or unauthorized use.

TEMIC TELEFUNKEN microelectronic GmbH, P.O.B. 3535, D-74025 Heilbronn, Germany  
Telephone: 49 (0)7131 67 2831, Fax number: 49 (0)7131 67 2423